

Liquid Trade Waste

Motor Trades

Category 2 Classification B



Definition

Liquid trade waste (LTW) is any discharge to a sewerage system other than domestic waste from a hand wash basin, shower, bath or toilet.

Central Coast Council is referred to as Council.

Introduction

This Fact Sheet is provided to assist you to treat and dispose of liquid trade waste in an efficient and approved manner.

For further information, please contact Council's Trade Waste Section on 4350 5555.

For LTW application forms, refer to www.centralcoast.nsw.gov.au.

Activities

Mechanical repair activities include the following facilities:

- A stand-alone garage
- A stand-alone mechanical workshop
- A service station workshop
- Lawnmower repairers that conduct mechanical repairs only and no other processes
- Motor boat repairers that conduct mechanical repairs only and no other processes
- Pre-treatment
- A collection well and non-emulsifying pump must be provided to collect:
- Water used for washing of mechanical equipment or parts
- Floor wash down

What pre-treatment is required?

The installation required to treat the waste water is a coalescing plate interceptor (CPI/CPS) with a minimum capacity of a 1000 L/h or a vertical gravity separator (VGS) or hydrocyclone separation system (HSS) sized according to the influent flow rate.

If your flow rate exceeds 1000 L/h, you will require a larger capacity and must provide supporting information regarding sizing and recommended maintenance schedule.

Make sure the unit is correctly installed, and where applicable the distributor or supplier must be able to guarantee supply of parts and service maintenance.

- Fit a basket arrestor or screen to all floor wastes that drain to the sewerage system, to strain out gross solids such as rags and packaging.
- If you cannot avoid using detergents, use only quick-break detergents, as oil arrestors are more efficient if detergents are not used.
- Clean using high water pressure where possible.
- Use only non-emulsifying pumps to pump the liquid waste to the separator.
- Do not discharge degreaser into the sewerage system.

NOTE: Double and triple interceptor pits and general purpose pits are not approved or appropriate pre-treatment equipment units for this type of wastewater.



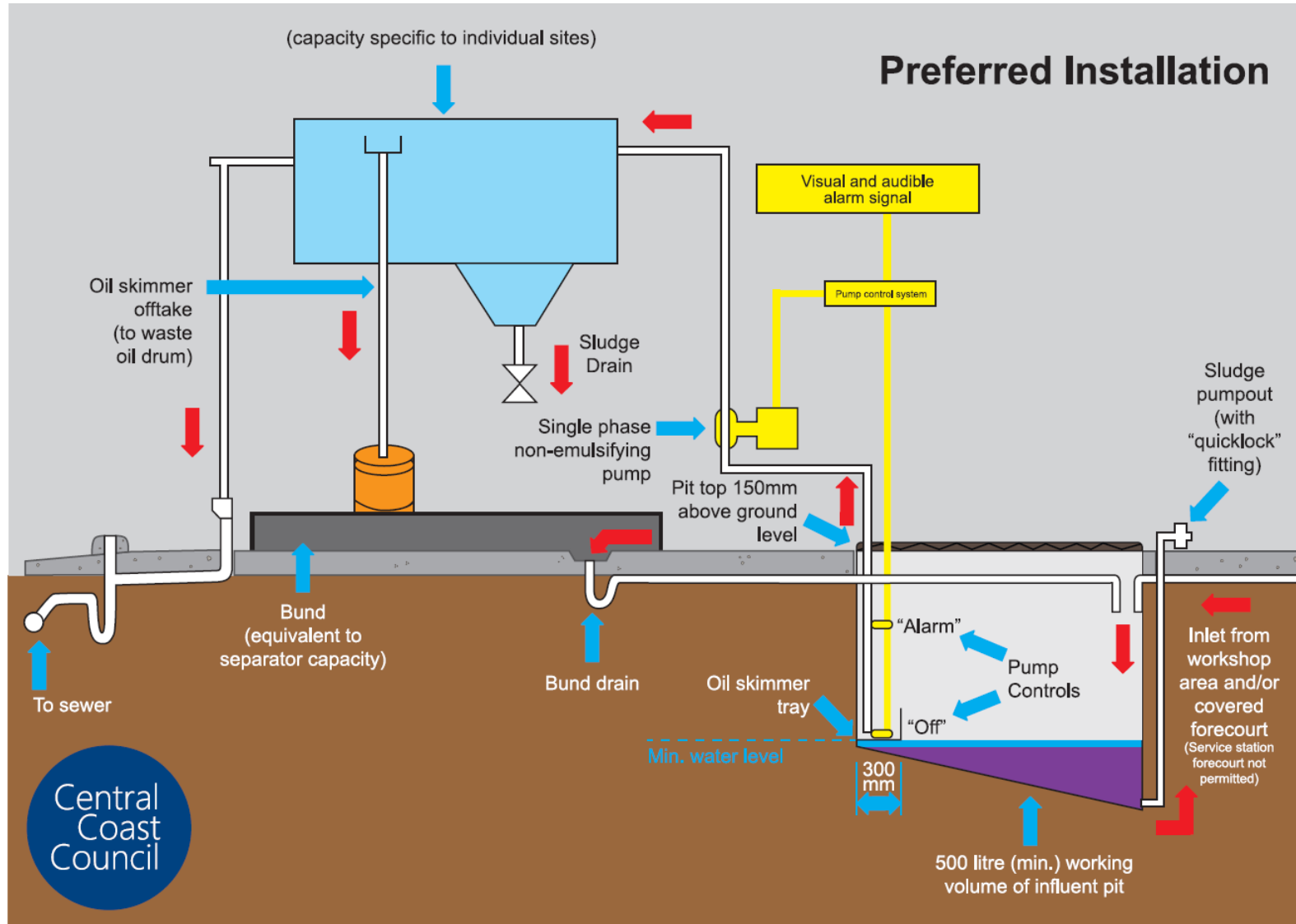

Wyong: 2 Hely St / PO Box 20 Wyong 2259 **P:** 02 4350 5555
Gosford: 40 Mann St / PO Box 21 Gosford 2250 **P:** 02 4325 8222
E: ask@centralcoast.nsw.gov.au **W:** centralcoast.nsw.gov.au

page 2



Coalescing Plate Interceptor (CPI)

Note:
This is an oily water separator.
All waste oils and coolants should be disposed via a licenced contractor and not put through the Coalescing Plate Interceptor (CPI) or discharged to sewer.

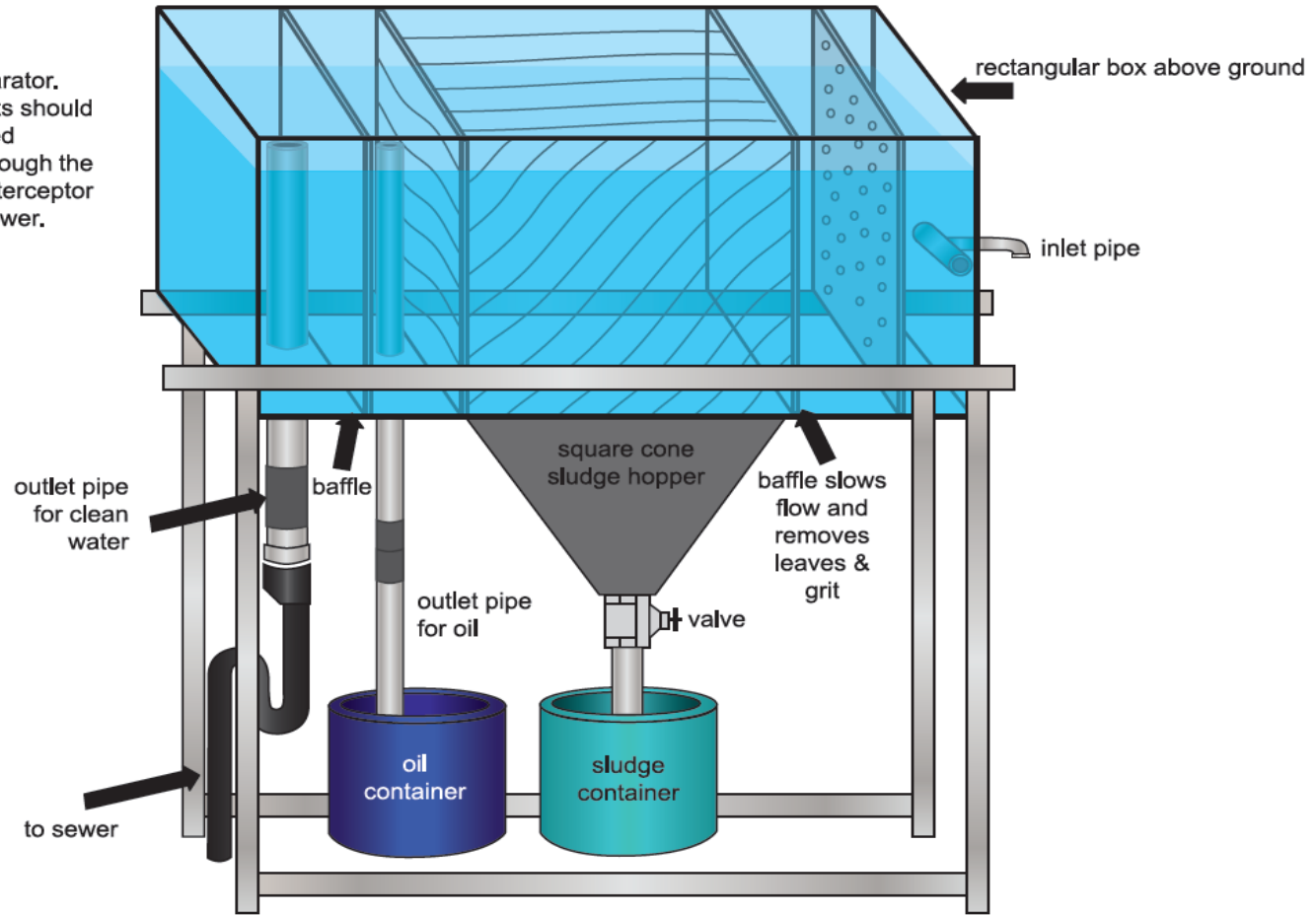

Stormwater

The wash area must be roofed to exclude rainwater from the sewerage system.

Make sure stormwater is diverted away from the wash area(s).

Housekeeping practices

- If you cannot avoid using detergents, use only quick-break detergents, to assist the separation process where any type of oil arrestor is used as pre-treatment
- Dry clean oil spills prior to wash down
- Scrape up grease blobs before wash down
- Consider using screens to exclude nuts, washers and the like from the pump intake
- Use only cleaning compounds that are compatible with the pre-treatment system
- Store oils, chemicals and solvents in a separate bunded area that cannot drain to the sewerage or stormwater systems

- Do not discharge petrol, diesel fuel, discrete oil, kerosene, solvents or any other flammable and/or explosive substances into the sewerage or stormwater system

Plumbing requirements

All plumbing should be installed as per Australian Standards AS/NZS 3500.2:2003 Plumbing and drainage – Sanitary plumbing and drainage.

For public health reasons, install all suitable backflow protection measures (or Mains Containment Protection) on the incoming water supply to the property. Such measures must be a Reduced Pressure Zone Device. Zone protection for prevention of backflow is recommended. The backflow protection measures must be approved and registered with Council.



Typical installation of Backflow Prevention Device

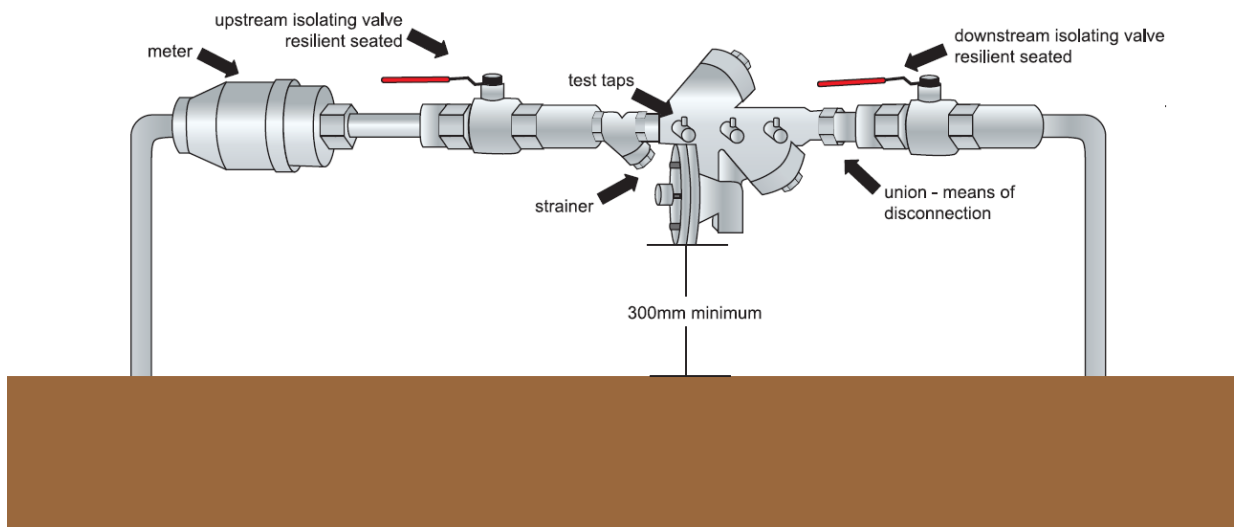

Business types

Activity	Characteristics of waste	Minimum Pre-Treatment Required
<ul style="list-style-type: none"> • Auto dismantler • Bus/Coach depot wash bay area • Car detailing • Mechanical workshop • Service stations (workshop only) • Vehicle washing (commercial-manual cleaning) • Vehicle washing (automatic robots) self service • Vehicle washing (including engine degreasing) 	<p>Oil, Grease, Suspended Solids, Petroleum Hydrocarbons, Metals, Solvents, Detergents</p> <p>Kerosene</p>	<p>Basket arrestor. Collection pit minimum capacity 300L. An oil interceptor/separator, sized accordingly.*</p> <p>Kerosene and solvents, if used, are not permitted into the sewer</p> <p>Reuse of wash water</p>
<ul style="list-style-type: none"> • Equipment hire company • Construction Equipment maintenance 	<p>Oil, Grease, Suspended Solids, Detergent, Kerosene</p>	<p>Basket arrestor. A general purpose pit or a solids settlement pit minimum size 1000L, an oil interceptor/separator, sized accordingly.*</p> <p>Kerosene is not permitted into the sewer.</p>
<ul style="list-style-type: none"> • Engine/gearbox reconditioning parts washing 	<p>Oil, Grease, Suspended Solids, Detergent, Kerosene, Lead</p>	<p>Basket arrestor. Collection pit minimum capacity 300L. An oil interceptor/separator, sized accordingly.*</p> <p>Kerosene is not permitted into sewer. Acid cracking, pH correction facility may be required.</p>



Activity	Characteristics of waste	Minimum Pre-Treatment Required
<ul style="list-style-type: none"> Panel beater/spray painting 	Oil, Grease, Suspended Solids	Basket arrestor. Collection pit minimum capacity 300L. An oil interceptor/separator, sized accordingly.* Discharge from a spray booth area is not permitted. Paint solvents, thinners are not permitted into the sewer.
<ul style="list-style-type: none"> Radiator repair 	Suspended Solids, pH, Metal	Solids settlement pit. Metal removal and pH adjustment may be required before discharge to sewer. <ol style="list-style-type: none"> Capture the radiator fluid in a tray or container before removing the radiator from the vehicle. Where possible, re-use radiator fluid, otherwise capture and store it for off-site removal by an EPA licenced contractor. Floor must be bunded to prevent spillage draining to sewer.
<ul style="list-style-type: none"> Service station covered forecourt Bus/Coach depot refuelling bay 	Exempt	Refer to Department of Industry Water, Water Circulation No. LWU13

*An oil interceptor/separator should be of an approved type such as a coalescing plate interceptor, a vertical gravity separator or hydrocyclone separation system sized accordingly to the influent flow rate. Nominal size is 1000 L/h. Only "quick-Break" detergents should be used. Refer to separate documents for installation requirements and other information on this equipment.

Wash area must be roofed, bunded and graded to exclude stormwater.





Application to Discharge Liquid Trade Wastes into Council's Sewerage System

OFFICE USE ONLY			
CATEGORY 1:		CATEGORY 2:	
Date:	Fee Paid \$	Licence No:	Debtor:
			HOT KEY:

For further enquiries on the application process, please contact the Liquid Trade Waste Supervisor on 4350 5515.

Business Trading Name				
Development Application No.	Lot No.	D.P.	Parcel No.	House No.
Street		Suburb		Postcode
Property Owner's Name			Telephone No. / Email	
Address				
Applicant's Name (if different from Property Owner)			Telephone No. / Email	
Applicant's Address (if different from Property Owner)				
Occupier's Name (if different from Property Owner)			Telephone No. / Email	

Principal Business Activity

Please supply a brief statement of the business type and processes generating liquid trade waste e.g. restaurant, mechanical workshop.		
Any water supply meter being installed? <input type="checkbox"/> Yes <input type="checkbox"/> No	Existing water meter number	Meter location

EXISTING / PROPOSED EQUIPMENT (GREASE ARRESTOR, BASKET ARRESTOR, COOLING PIT, CPI, VGS, ETC)

Type	Size/flow rate
------	----------------

PROPOSED CLEANING SCHEDULE OF PRE-TREATMENT EQUIPMENT AND NAMES OF CONTRACTORS USED

Pre-treatment equipment	Frequency (weeks)
Name of Contractor	Contact number
Location of pre-treatment device (sample point if required, CPI, VGS)	

Refer to Council's [Liquid Trade Waste Policy](#) for the Liquid Trade Waste Quality Standards, which lists pollutants and their allowable limits



SUBSTANCES PROHIBITED FROM BEING DISCHARGED TO THE SEWERAGE SYSTEM

The following substances are prohibited from being discharged to the sewerage system:

- organochlorine weedicides, fungicides, pesticides, herbicides and substances of a similar nature and/or wastes arising from the preparation of these substances
- organophosphorus pesticides and/or waste arising from the preparation of these substances
- any substances liable to produce noxious or poisonous vapours in the sewerage system
- organic solvents and mineral oil
- any flammable or explosive substances
- discharges from 'Bulk Fuel Depots'
- chromate from cooling towers
- natural or synthetic resins, plastic monomers, synthetic adhesives, rubber and plastic emulsions
- rain, surface, seepage or subsoil water, unless specifically permitted
- solid matter
- any substance assessed as not suitable to be discharged to the sewerage system
- waste liquids that contain pollutants at concentrations which inhibit the sewage treatment process – refer *National Wastewater Source Management Guideline, July 2008, WSAA*
- any other substances listed in a relevant regulation.

CHECKLIST FOR APPLICATIONS

1. Completed application with owner's signature
2. Two copies of plans showing:
 - Details and location of all processes, tanks, pits and apparatus associated with the generation of commercial waste
 - Details, location, capacity / dimensions, material of construction and lining of the proposed pre-treatment facilities
 - Details of pipes and floor drainage conveying the effluent
 - Stormwater drainage plan
3. Nature of processes of the business attached
4. Any other relevant supporting documents e.g.
 - Environmental Impact Statement
 - Consultant's Report
 - EPA consideration / restrictions
 - Details of chemicals being used and SDS

Signature of Property Owner/s

Owner's authorisation to making the application is mandatory as per Section 78 of the *Local Government Act 1993*

Please note that the owner of the property will be billed for water supply, sewerage and liquid trade waste services provided and it is the owner's responsibility to pay such fees and charges within the period specified. The owner may arrange to recover such fees and charges through the lease agreement between the owner and the occupier.

The applicant should be aware that approval of this application does not constitute a guarantee of any future approval of a variation to the approval. This will be dependent on the available capacity of the sewerage system at that time and any future approval must not be assumed. However, alerting the Council to the applicant's future plans and proposals may assist the Council in planning future sewage management and / or infrastructure additions / modifications.

Signature of occupier / applicant

Position in company

Date

