

# Liquid Trade Waste

Commercial retail food outlets generating greasy oily wastes  
Category 2 Classification A

## Definition

**Liquid trade waste (LTW)** is any discharge to a sewerage system other than domestic waste from a hand wash basin, shower, bath or toilet.

## Introduction

This Fact Sheet is provided to assist you to treat and dispose of liquid trade waste in an efficient and approved manner.

Central Coast Council is referred to as Council.

For further information, please contact Council's Trade Waste Section on 4350 5555.

For LTW application forms, refer to [www.centralcoast.nsw.gov.au](http://www.centralcoast.nsw.gov.au).

## Activities

Discharges from commercial retail food preparation activities are divided into two groups:

- Activities that **do not** generate greasy/oily types of waste
- Activities that **do** generate greasy/oily types of waste.

Greasy/oily types of wastes can be generated by:

- cooking food on site, with the cooking process generating a grease or oily residue
- preparing food on site, with the preparation process resulting in greasy/oily or fatty waste residuals on utensils and equipment (this includes the making of creams and custards for topping or filling cakes, pies and pastries)

- serving cooked food for consumption on site that has been prepared or cooked either on site or elsewhere, with the served food generating a grease or oily residue

Premises that serve only fresh and toasted sandwiches, wraps, or import pies, sausage rolls and other pastry products and heat these for take-away consumption **do not** fall under greasy/oily type of waste. Requirements for this type of premises are outlined in a separate fact sheet.

## What pre-treatment is required?

### Grease arrester

You must have a 1000L capacity grease arrester or equivalent approved pre-treatment device if you discharge less than 1100 litres per day (1100 L/d). It is generally accepted that where seating or beds are provided, if there are less than 69 seats or beds, the discharge will be less than 1100 L/d.

Activities not listed with any daily flow values are likely to generate a liquid trade waste volume in excess of 1100L/d and will require a larger-sized grease arrester. For example, a cooking process involving a wok burner may generate high volumes of waste water and the minimum size of the grease arrester required would be 1500L. Fast food outlets such as McDonalds, Red Rooster and KFC require grease arrestors with a minimum capacity of 1500L. Barbecuing processes with steam ovens or gas vats require a grease arrester with a minimum capacity of 2000L.



If you have a dishwasher (or dishwashers) on the premises, allow 250L for each dishwashing cycle when considering the required size of the grease arrestor.

If you propose to install an equivalent approved pre-treatment device (ie a device other than an approved boat-shaped grease arrestor), your application must include a written statement from the distributor or supplier guaranteeing the supply of parts and service maintenance.

### Sink and floor wastes

Connect floor wastes to the grease arrestor or equivalent approved pre-treatment equipment, in food preparation areas.



### Barbecuing Process

Collect fat and oil from barbecuing processes as well as any other waste oil generated, to ensure they are not discharged into the grease arrestor. Only waste water generated from the cleaning of cooking equipment may be discharged to the sewerage system via the grease arrestor.

You must have an oil collection container underneath the cooking equipment or install an oil collection system for the collection of fat and oil produced during cooking. Empty the collected oil into a container every day (or as necessary) for collection by an Environment Protection Authority (EPA) authorised oil recycler.

If your business has chicken, duck and meat barbecuing facilities with a steam oven or gas vat, you must have an oil and fat interceptor upstream from the grease arrestor.

### Housekeeping practices

- Dry sweep floors before washing to avoid wastes being caught up in the wash water discharged down the drain to the sewerage system
- Pre-wipe utensils, plates, bowls etc to the scrap bin before washing up to minimise the amount of waste put down the drain
- **Do not use food waste disposal units** (also known as insinkerators, in-sink food waste disposers or garbage grinders) or any form of macerator



## Storage of oil and chemicals

Store oil and cleaning chemicals where any spillage cannot drain to the sewerage or stormwater systems. Collect used oil and fats and arrange removal from the premises by an authorised oil and fat recycler.

## Plumbing requirements

All plumbing must be installed as per Australian Standards AS/NZS 3500.2:2003 Plumbing and drainage – Sanitary plumbing and drainage.

For public health reasons, the installation of suitable backflow protection measures (or Mains Containment Protection) must be undertaken on the incoming water supply to the property, using a Reduced Pressure Zone Device. Zone protection for prevention of backflow is recommended. The backflow protection measures must be approved and registered with Council.



## Typical installation of Backflow Prevention Device

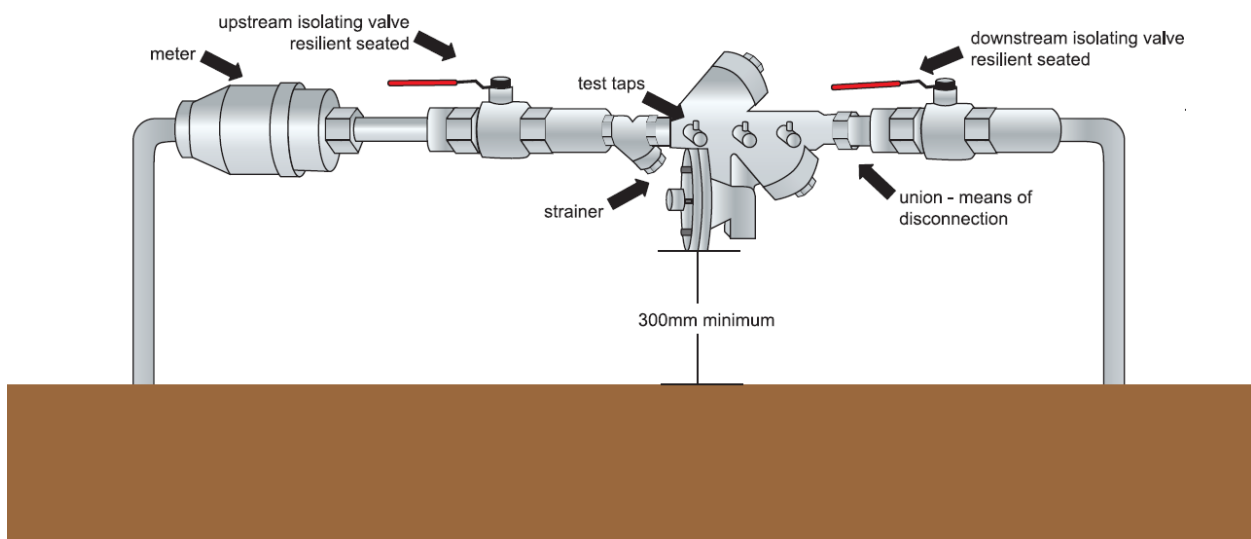

# Example of Grease Arrestor drainage layout

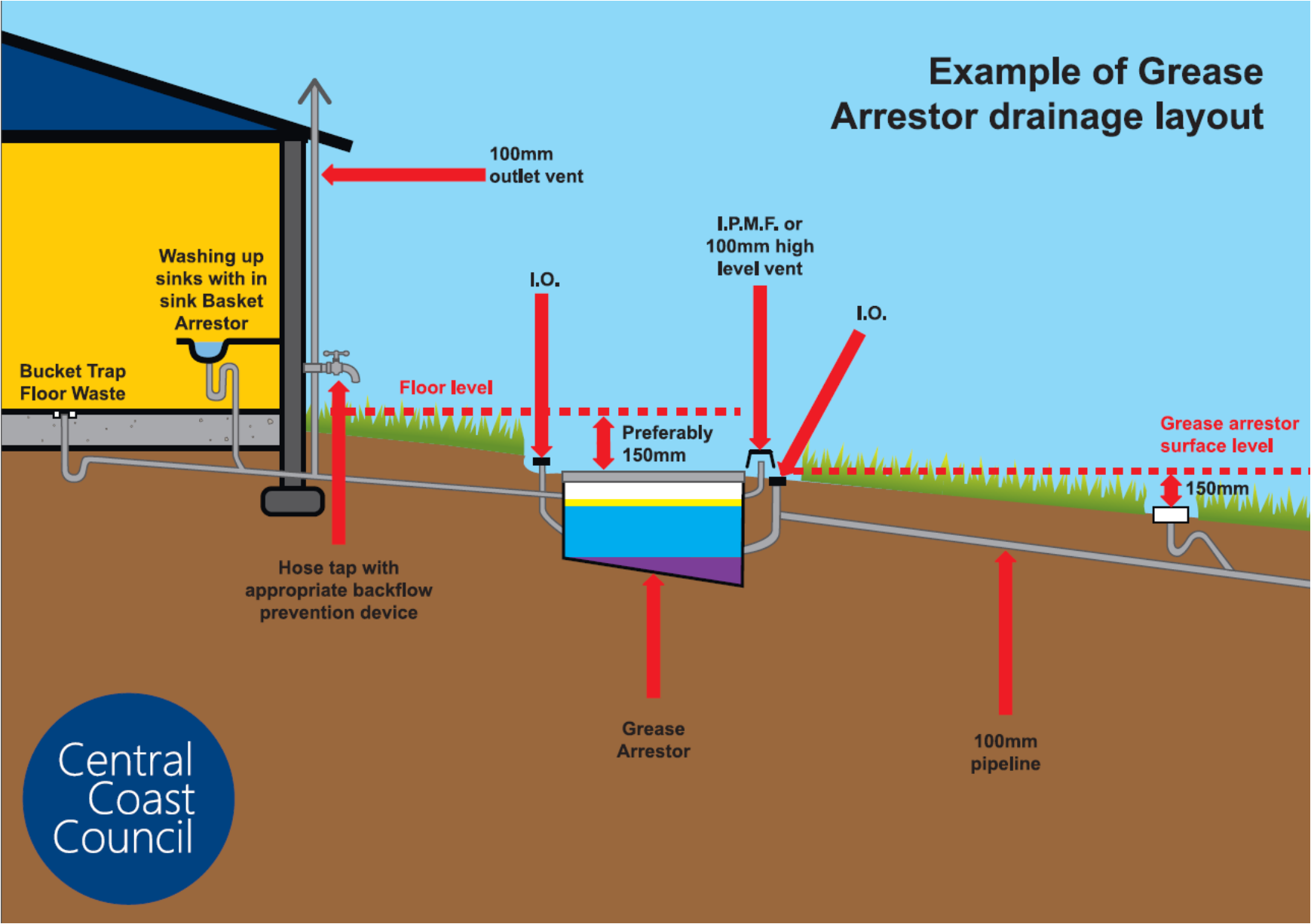

## Business Types

Activity	Required Minimum Pre-treatment
<b>Bakery</b> <ul style="list-style-type: none"> <li>pies, sausage rolls, quiches, cakes, pastries with creams or custards</li> </ul>	<ul style="list-style-type: none"> <li>1000L Grease arrester (minimum)</li> <li>Basketarrester with fixed screens for all floor wastes in food preparation areas</li> <li>Sink screen/strainers</li> </ul>
<b>Bistro</b> <ul style="list-style-type: none"> <li>With hot food</li> </ul>	<ul style="list-style-type: none"> <li>1000L Grease arrester (minimum)</li> <li>Basket arrester with fixed screens for all floor wastes in food preparation areas</li> <li>Sink screen/strainers</li> </ul>
<b>Boarding house/hostel kitchen</b>	<ul style="list-style-type: none"> <li>1000L Grease arrester (minimum)</li> <li>Basket arrester with fixed screens for all floor wastes in food preparation areas</li> <li>Sink screen/strainers</li> </ul>
<b>Butcher</b>	<ul style="list-style-type: none"> <li>1000L Grease arrester (minimum)</li> <li>Basket arrester with fixed screens for all floor wastes in food preparation areas</li> <li>Sink screen/strainers, all drains from sinks to pass through dry basket arrester</li> </ul>
<b>Café/coffee shop/coffee lounge</b> <ul style="list-style-type: none"> <li>With hot food</li> </ul>	<ul style="list-style-type: none"> <li>1000L Grease arrester (minimum)</li> <li>Basket arrester with fixed screens for all floor wastes in food preparation areas</li> <li>Sink screen/strainers</li> </ul>
<b>Canteen</b> <ul style="list-style-type: none"> <li>With hot food</li> </ul>	<ul style="list-style-type: none"> <li>1000L Grease arrester (minimum)</li> <li>Basket arrester with fixed screens for all floor wastes in food preparation areas</li> <li>Sink screen/strainers</li> </ul>
<b>Cafeteria</b> <ul style="list-style-type: none"> <li>With hot food</li> </ul>	<ul style="list-style-type: none"> <li>1000L Grease arrester (minimum)</li> <li>Basket arrester with fixed screens for all floor wastes in food preparation areas</li> <li>Sink screen/strainers</li> </ul>
<b>Chicken/poultry shop</b> <ul style="list-style-type: none"> <li>Retail BBQ/charcoal chicken</li> </ul>	<ul style="list-style-type: none"> <li>1000L Grease arrester (minimum)</li> <li>2000L Grease arrester minimum for steam oven or gas vat BBQ process</li> <li>For steam oven or gas vat, an oil and fat interceptor is required upstream of the grease arrester</li> <li>Basket arrester with fixed screens for all floor wastes in food preparation areas</li> <li>Sink screen/strainers</li> </ul>
<ul style="list-style-type: none"> <li>Only fresh chickens for retail with cutting and preparation of meat on-site</li> </ul>	<ul style="list-style-type: none"> <li>1000L Grease arrester (minimum)</li> <li>Dry basket arrester with fixed screens for all floor wastes in food preparation areas</li> <li>Sink screen/strainers</li> </ul>
<b>Club</b> <ul style="list-style-type: none"> <li>With hot food</li> </ul>	<ul style="list-style-type: none"> <li>1000L Grease arrester (minimum). Size to be determined by the venue's capacity for the maximum amount of seats that can be installed</li> <li>Basket arrester with fixed screens for all floor wastes in food preparation areas</li> <li>Sink screen/strainers</li> </ul>
<b>Commercial Kitchen/caterer</b>	<ul style="list-style-type: none"> <li>1000L Grease arrester (minimum)</li> <li>Basket arrester with fixed screens for all floor wastes in food preparation areas</li> <li>Sink screen/strainers</li> </ul>
<b>Community hall/civic centre</b> <ul style="list-style-type: none"> <li>With hot food</li> </ul>	<ul style="list-style-type: none"> <li>1000L Grease arrester (minimum). Size to be determined by the venue's capacity for the maximum amount of seats that can be installed</li> <li>Basket arrester with fixed screens for all floor wastes in food preparation areas</li> <li>Sink screen/strainers</li> </ul>



Activity	Required Minimum Pre-treatment
<b>Day care centre</b> <ul style="list-style-type: none"> <li>• With hot food</li> </ul>	<ul style="list-style-type: none"> <li>• 1000L Grease arrester (minimum)</li> <li>• Basket arrester with fixed screens for all floor wastes in food preparation areas</li> <li>• Sink screen/strainers</li> </ul>
<b>Delicatessen</b> <ul style="list-style-type: none"> <li>• With hot food</li> </ul>	<ul style="list-style-type: none"> <li>• 1000L Grease arrester (minimum)</li> <li>• Basket arrester with fixed screens for all floor wastes in food preparation areas</li> <li>• Sink screen/strainers</li> </ul>
<b>Doughnut shop</b>	<ul style="list-style-type: none"> <li>• 1000L Grease arrester (minimum)</li> <li>• Basket arrester with fixed screens for all floor wastes in food preparation areas</li> <li>• Sink screen/strainers</li> </ul>
<b>Fast food outlets</b> <ul style="list-style-type: none"> <li>• Burger King, KFC, McDonalds, Pizza Hut, Red Rooster, etc</li> </ul>	<ul style="list-style-type: none"> <li>• 1500L Grease arrester (minimum)</li> <li>• Basket arrester with fixed screens for all floor wastes in food preparation areas</li> <li>• Sink screen/strainers</li> </ul>
<b>Fish shop</b> <ul style="list-style-type: none"> <li>• With hot food</li> </ul>	<ul style="list-style-type: none"> <li>• 1000L Grease arrester (minimum)</li> <li>• Basket arrester with fixed screens for all floor wastes in food preparation areas</li> <li>• Sink screen/strainers, all drains from sinks to pass through dry basket arrester</li> </ul>
<b>Food caravan</b>	<ul style="list-style-type: none"> <li>• 1000L Grease arrester (minimum)</li> <li>• Basket arrester with fixed screens for all floor wastes in food preparation areas</li> <li>• Sink screen/strainers</li> </ul>
<b>Function centre</b>	<ul style="list-style-type: none"> <li>• 1000L Grease arrester (minimum). Size to be determined by the venue's capacity for the maximum amount of seats that can be installed</li> <li>• Basket arrester with fixed screens for all floor wastes in food preparation areas</li> <li>• Sink screen/strainers</li> </ul>
<b>Hotel</b> <ul style="list-style-type: none"> <li>• With hot food</li> </ul>	<ul style="list-style-type: none"> <li>• 1000L Grease arrester (minimum)</li> <li>• Basket arrester with fixed screens for all floor wastes in food preparation areas</li> <li>• Sink screen/strainers</li> </ul>
<b>Ice-cream parlour</b> <ul style="list-style-type: none"> <li>• Serve on site</li> </ul>	<ul style="list-style-type: none"> <li>• 1000L Grease arrester (minimum)</li> <li>• Basket arrester with fixed screens for all floor wastes in food preparation areas</li> <li>• Sink screen/strainers</li> </ul>
<b>Motel</b> <ul style="list-style-type: none"> <li>• With hot food</li> </ul>	<ul style="list-style-type: none"> <li>• 1000L Grease arrester (minimum)</li> <li>• Basket arrester with fixed screens for all floor wastes in food preparation areas</li> <li>• Sink screen/strainers</li> </ul>
<b>Nightclub</b> <ul style="list-style-type: none"> <li>• With hot food</li> </ul>	<ul style="list-style-type: none"> <li>• 1000L Grease arrester (minimum)</li> <li>• Basket arrester with fixed screens for all floor wastes in food preparation areas</li> <li>• Sink screen/strainers</li> </ul>
<b>Nursing home kitchen</b>	<ul style="list-style-type: none"> <li>• 1000L Grease arrester (minimum)</li> <li>• Basket arrester with fixed screens for all floor wastes in food preparation areas</li> <li>• Sink screen/strainers</li> </ul>
<b>Patisserie, croissants and muffins</b>	<ul style="list-style-type: none"> <li>• 1000L Grease arrester (minimum)</li> <li>• Basket arrester with fixed screens for all floor wastes in food preparation areas</li> <li>• Sink screen/strainers</li> </ul>
<b>Pie shop</b>	<ul style="list-style-type: none"> <li>• 1000L Grease arrester (minimum)</li> <li>• Basket arrester with fixed screens for all floor wastes in food preparation areas</li> <li>• Sink screen/strainers</li> </ul>



Activity	Required Minimum Pre-treatment
<b>Pizza</b> <ul style="list-style-type: none"> <li>Pizzeria</li> <li>Pizza cooking</li> </ul>	<ul style="list-style-type: none"> <li>1000L Grease arrester (minimum)</li> <li>Basket arrester with fixed screens for all floor wastes in food preparation areas</li> <li>Sink screen/strainers</li> </ul>
<b>Restaurant</b>	<ul style="list-style-type: none"> <li>1000L Grease arrester (minimum)</li> <li>Basket arrester with fixed screens for all floor wastes in food preparation areas</li> <li>Sink screen/strainers</li> </ul>
<b>Sandwich shop/salad bar/Snack bar</b> <ul style="list-style-type: none"> <li>With hot food</li> </ul>	<ul style="list-style-type: none"> <li>1000L Grease arrester (minimum)</li> <li>Basket arrester with fixed screens for all floor wastes in food preparation areas</li> <li>Sink screen/strainers</li> </ul>
<b>Primary School</b> <ul style="list-style-type: none"> <li>Canteen with hot food cooking</li> </ul>	<ul style="list-style-type: none"> <li>1000L Grease arrester (minimum)</li> <li>Basket arrester with fixed screens for all floor wastes in food preparation areas</li> <li>Sink screen/strainers</li> </ul>
<b>Secondary School</b> <ul style="list-style-type: none"> <li>Canteen with hot food cooking</li> <li>Home science cooking</li> </ul>	<ul style="list-style-type: none"> <li>1000L Grease arrester (minimum)</li> <li>Basket arrester with fixed screens for all floor wastes in food preparation areas</li> <li>Sink screen/strainers</li> </ul>
<b>Supermarket</b> <ul style="list-style-type: none"> <li>Butcher/ delicatessen/ seafood</li> </ul>	<ul style="list-style-type: none"> <li>1000L Grease arrester (minimum)</li> <li>Basket arrester with fixed screens for all floor wastes in food preparation areas</li> <li>Sink screen/strainers, all drains from sinks to pass through dry basket arrester</li> </ul>
<ul style="list-style-type: none"> <li>BBQ chickens</li> </ul>	<ul style="list-style-type: none"> <li>1000L Grease arrester (minimum), 2000L minimum capacity for steamoven or gas BBQ process</li> </ul>
<b>Take away food outlet</b> <ul style="list-style-type: none"> <li>With hot food</li> </ul>	<ul style="list-style-type: none"> <li>1000L Grease arrester (minimum)</li> <li>Basket arrester with fixed screens for all floor wastes in food preparation areas</li> <li>Sink screen/strainers</li> </ul>

### Determination of a grease arrester size

Type of business	Minimum Size
<b><i>Café, canteen, restaurant, club, function centre, hotel (hot food preparation)</i></b>	
discharge up to 1100 L/d, typically up to 69 seats	1000L
discharge up to 3200 L/d, typically up to 70-199 seats	1500L
discharge up to 6400 L/d, typically up to 200-399 seats	2000L
discharge up to 9600 L/d, typically up to 400-599 seats	3000L
discharge up to 12,800 L/d, typically up to 600-799 seats	4000L
discharge up to 16,000 L/d, typically up to 800-1000 seats	5000L
<b><i>Fast food outlets</i></b>	
Burger King, KFC, McDonalds, Red Rooster, Pizza Hut, etc.	1500L





<b><i>Barbecuing Process</i></b>	
Rotisserie, charcoal BBQ, hot plate	1000L
Steam oven, gas vat	2000L
<b><i>Restaurant, food outlets with a Wok Burner</i></b> <i>(applicable where large volumes of water are discharged)</i> Sized according to a flow rate	1500L
<b>Motel: room service provided</b>	
up to 50 rooms	1000L
up to 100 rooms	1500L
up to 200 rooms	2000L
up to 300 rooms	3000L
<b><i>Hospital, hostel, nursing home</i></b>	
discharge up to 1100 L/d, typically up to 69 beds	1000L
discharge up to 3200 L/d, typically up to 70-199 beds	1500L
discharge up to 6400 L/d, typically up to 200-399 beds	2000L
discharge up to 9600 L/d, typically up to 400-599 beds	3000L
discharge up to 12,800 L/d, typically up to 600-799 beds	4000L
discharge up to 16,000 L/d, typically up to 800-1000 beds	5000L
<b><i>Shopping centres and food halls</i></b>	
Where common grease arrestors are to be installed, the capacity of the arrestor should be at least 60% of the estimated capacity for the shops if they were to stand alone.	
<b><i>Example: Shopping centre with four stand-alone businesses</i></b>	
Take-away food	1000L
Butcher shop	1000L
Cafeteria (50 seats)	1000L
KFC	1500L
<b>Total</b>	<b>4500L</b>
The total capacity of the grease traps to service these businesses at a shopping centre must not be less than 60% of 4500L, i.e. 270 L. This capacity can be provided by one 3000L arrestor or by a combination of smaller-size units. Premises will have to be grouped to drain to separate grease arrestors. Care should be taken when grouping shops so that the capacity of the arrestor is sufficient for a certain group but will also allow for future additional food businesses.	Size required 3000L

