

DCP No.  
111

# Hoardings Development Control Plan

DRAFT

**This Development Control Plan (DCP) may be amended from time to time by Council. Proposed amendments are required to be advertised and exhibited in draft form and any submissions received must be considered by Council before the amended plan is adopted. People using this DCP should ensure that they have the current copy of the plan, including any amendments. If in doubt, please check with Council's Customer Service Centre.**

Adopted as per council resolution Dated:	
Effective:	
Certified in accordance with the Environmental Planning and Assessment Act 1979 and Regulations	General Manager:
	Dated:

## TABLE OF CONTENTS

<b>1.0</b>	<b>INTRODUCTION</b>	<b>3</b>
1.1	Aims and Objectives	3
1.2	Application of this Plan	3
1.3	Preamble	4
1.4	Definitions	4
<b>2.0</b>	<b>HOARDING AND ACCESS SPECIFICATIONS</b>	<b>5</b>
2.1	“A” type hoarding	5
2.2	“B” type hoarding	5
2.3	“C” Type Hoarding	6
2.4	Footway site access	6
<b>3.0</b>	<b>APPLICATIONS</b>	<b>7</b>
3.1	Council Approval	7
3.2	Conditions	7
3.3	Fees	7
<b>4.0</b>	<b>APPENDICES</b>	<b>8</b>
<b>A</b>	<b>Conditions of Approval</b>	<b>8</b>

Formatted: Not Highlight

**Deleted: 1.0 .**  
**INTRODUCTION . 3¶**  
 1.1 . Aims and Objectives . 3¶  
 1.2 . Application of this Plan . 3¶  
 1.3 . Preamble . 4¶  
 1.4 . Definitions . 4¶  
**2.0 . HOARDING AND**  
**ACCESS SPECIFICATIONS . 5¶**  
 2.1 . “A” type hoarding . 5¶  
 2.2 . “B” type hoarding . 5¶  
 2.3 . “C” Type Hoarding . 6¶  
 2.4 . Footway site access . 6¶  
**3.0 . APPLICATIONS . 7¶**  
 3.1 . Council Approval . 7¶  
 3.2 . Conditions . 7¶  
 3.3 . Fees . 7¶  
**4.0 . APPENDICES . 8¶**  
**A . Conditions of Approval . 8¶**

# 1.0 INTRODUCTION

## 1.1 Aims and Objectives

This plan aims to provide for the overall management of hoardings within Wyong Shire by:

- Identifying Council's requirements for the erection, management and removal of hoardings required in development applications;
- Identifying standards and techniques which are required for the erection, management and removal of hoardings in Wyong Shire;
- Promoting best practice relating to the erection, management and removal of hoardings;
- Providing standards which will protect public footways, roads and the like from the hazards of building sites;
- Ensuring activities on properties do not obstruct the safe use of public footways, roads and the like; and
- Requiring the erection of hoardings for activities such as cleaning, repairing and other maintenance works associated with properties adjacent to a public footway, roadway or the like.

## 1.2 Application of this Plan

This plan is a Development Control Plan (DCP) prepared and adopted pursuant to Section 72 of the Environmental Planning and Assessment Act 1979 (the Act) and relevant clauses of the Environmental Planning and Assessment Regulation 2000. It is a document for the general guidance of Council in the exercise of its duties and functions under the Act. The plan applies to all land in the Shire of Wyong to which Wyong Local Environmental Plan 1991 (WLEP, 1991) applies.

This plan is to be read in conjunction with NSW Workcover's Code of Practice – Overhead Protective Structures 20 March 1995, or the most current version of such document.

In circumstances where there may be any inconsistency between the requirements contained in this plan and any other Council development control plan, the provisions of this plan shall apply.

Where development is proposed pursuant to any Environmental Planning Instrument, Council will require submission of an application to erect a hoarding. In circumstances where there may be any inconsistency between the requirements contained in this plan and any other Council Development Control Plan relating to the erection, management and removal of hoardings, the provisions of this plan shall apply.

### 1.3 Preamble

The design, supply and installation of construction hoardings are guided presently through the Code of Practice - Overhead Protective Structures produced by the WorkCover Authority of NSW. This Code is aimed at improving health and safety standards on new building and construction sites, as required by the Occupational Health and Safety Act 1983.

The Code of Practice - Overhead Protective Structures refers to additional requirements of the local Council and acknowledges Council's role in reviewing and inspecting the installation of construction hoardings in public areas. This plan is not a substitute for the Code prepared by WorkCover, but is a supplement to it.

Where a hoarding is required to be constructed by WorkCover on or over public land the hoarding must comply with the requirements of this plan. Council may also require a hoarding to be erected for the purpose of public safety.

Businesses seeking to construct hoardings on Council's roads and footpaths must obtain prior approval from Wyong Shire Council and comply with all conditions of the approval and this plan.

Where a hoarding is required to be constructed on a Classified Road Council must seek the concurrence of the Roads and Traffic Authority (RTA) in accordance with section 138 of the Roads Act 1993.

### 1.4 Definitions

For the purpose of this policy, the following definition applies:

~~"A" type hoarding means a vertical protective structure constructed in timber, or other approved materials and is at least 2100mm in height.~~

"B" type hoarding refers to overhead protective structures.

"C" type hoarding refers to Type 'B' Hoardings with overhead sheds or storage.

"Hoardings" are structures erected on or adjacent to a property to form a barrier between building / demolition sites and the adjoining land.

Hoarding structures can consist of fences; scaffolding or overhead structures as individual elements or integrated together.

A hoarding comprising a fence is known as a Type A, an overhead structure situated over footpaths is known as a Type B and a Type C being a full-face scaffold.

"DCP" Development Control Plan

Formatted: Not Highlight

Formatted: Font: Not Bold

Formatted: Font: Not Bold

Deleted: ¶  
"A" type hoarding means a structure constructed of 100mm x 50mm posts at approximately 600mm centres and 100mm x 50mm tongue and grooved. The frame must be covered with 25mm tongue and grooved timber or plywood or other approved material and be at least 2,100mm in height.

## 2.0 HOARDING AND ACCESS SPECIFICATIONS

### 2.1 “A” type hoarding

~~Type “A” hoardings must be constructed where demolition, building, maintenance or other works are being carried out on a building.~~ The individual hoarding panels must be bolted together to form a continuous barrier complete with end returns. The hoarding must be suitably braced and counter weighed for stability against wind and other loads, and comply with the conditions of consent outlined in Appendix A and attached to the hoarding permit.

‘A’ type hoardings shall be constructed in all cases other than where type ‘B’ is needed, and where buildings within 3.5 metres of the street alignment are being altered, also where land abutting a public way is being excavated below the level of such public way where excavation will be within 3H:1V of public way.

‘A’ type hoardings shall be permitted to encroach upon the public way provided that Council is empowered to permit a hoarding to be erected at a greater distance from the property boundary if any particular case warrants such consideration.

Notwithstanding Council is empowered to:

- (a) restrict the projection on the public way in order to provide ample width of footway for pedestrians and
- (b) require the erection of hoardings in any other case where deemed necessary for the protection of the public.

### 2.2 “B” type hoarding

Upon completion “B” type hoardings shall be certified by a Structural Engineer to ensure they are constructed in accordance with the NSW WorkCover Authority Code of Practice. All other non-structural provisions of this Code shall be complied with. This document can be viewed at the Authorities web site at <http://www.workcover.nsw.gov.au>

“B” type hoardings must comply with the conditions of consent (standard conditions) as attached to the hoarding permit.

“B” type overhead hoardings shall be constructed where buildings over two (2) stories or 6 metres in height above the footpath level and within 3.5 metres of the property boundary are being erected or demolished or where the outer part of such buildings adjoining a public way is being altered or maintenance carried out.

Where the height of the building or the position of the site is such that danger is likely to occur from falling objects, additional safety hoardings shall be provided to the satisfaction of Council. In special cases, where the width of the footway is less than 2.5 metres or where the erection of a standard ‘B’ class hoarding is impracticable, the applicant shall submit plans of a suitable cantilever hoarding for the approval of Council. ‘B’ type hoarding shall also be constructed where material is being hoisted over or across a public way.

Formatted: Not Highlight

Deleted: ¶

Formatted: Font: 10 pt

Formatted: Font: 10 pt

Formatted: Font: 10 pt

Formatted: Font: 10 pt

Deleted: “A” type hoarding means a structure constructed of 100mm x 50mm posts at approximately 600mm centres and 100mm x 50mm tongue and grooved. The frame must be covered with 25mm tongue and grooved timber or plywood or other approved material and be at least 2,100mm in height.

Formatted: Not Highlight

### 2.3 “C” Type Hoarding

“C” type hoarding must comply with the conditions of approval outlined in Appendix A and attached to the hoarding approval.

“C” type hoardings comprise Type ‘B’ Hoardings with overhead sheds or storage.

### 2.4 Footway site access

Footway site access must be protected from damage by vehicles by the installation of timber crossings, or an alternate design approved by Council as the Roads Authority e.g. 4500mm wide 200mm x 50mm planks with 170mm splayed edges held together by four (4) strands or hoop iron. Such crossings must cover the full width of the footway and full width of access. The builder is to ensure footways and kerbs are protected from damage at all times. See Figure 1.

Formatted: Not Highlight

Deleted: 75

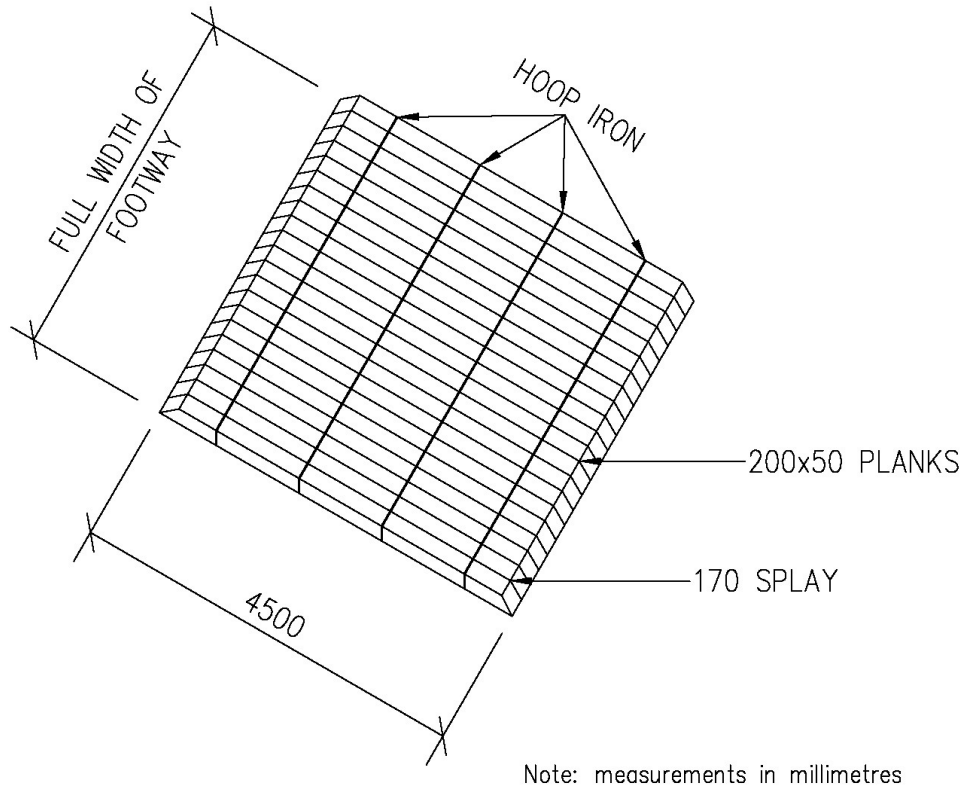

Figure 1 Example of Footway Site Access

## 3.0 APPLICATIONS

### 3.1 Council Approval

Prior to the erection of any hoarding or site access arrangement the approval of Council must be obtained. Such application shall be made by way of the application form available from Council Customer Service Section.

Evidence of Public Liability Insurance indemnifying Council is to be submitted to Council with the application.

### 3.2 Conditions

Council as part of issuing an approval to allow occupation of a hoarding may impose conditions relating to the erection, management and removal of the hoarding and/or site access.

Standard conditions are outlined in Appendix A at the rear of this Plan.

### 3.3 Fees

Fees are to be paid for each application in accordance with Council's Management Plan, which can be viewed on Council's website at [www.wyong.nsw.gov.au](http://www.wyong.nsw.gov.au)

Information regarding fees can be obtained by contacting Council's Customer Service Centre on 02 4350 5555 during normal business hours.

## 4.0 APPENDICES

### A Conditions of Approval

#### Conditions of Consent to Allow Occupation of a Hoarding.

1. If the proposed hoarding affects any street light or wiring, the applicant must consult and comply with any conditions imposed by the appropriate service authority before erecting the hoarding.

2. The holder of this Approval must book an inspection via Council's Customer Service, by phone, of the proposed dismantling of the hoarding at least one full business day prior to the commencement of the removal of the hoarding.

3. **Type of Hoarding** – The hoardings and fences shall be in accordance with the design and specification adopted by the Council.

#### 4. Maintenance

(a) Hoardings shall remain in place until the construction of the building is completed, or in the case of a demolition until the building is completely demolished.

(b) Hoardings shall be painted white or whitewashed and kept clean to the satisfaction of Council.

(c) Suitable lighting shall be affixed to the ends of the hoardings, in the case of type "B" or "C" hoarding above any undercroft that encompasses a footway or pedestrian thoroughfare and also at other positions if required by Council. Illumination is required from sunset to sunrise.

(d) No advertisements of any kind shall be affixed to hoarding/s with the exception of a board not exceeding 2.5 metres x 2 metres on which may be shown the Architect's and Builder's names or any particulars regarding the subject building, and notices regarding the existing or future occupancies in the building.

(e) A sign "BILLPOSTERS WILL BE PROSECUTED" shall be attached or printed upon the front of the hoarding at 5 metre intervals.

(f) Hydrant or other footpath box(s) shall not be covered in any way or access to same impeded and their position shall be marked in a visible position in the hoarding face. The sketch plan accompanying this application shall mark the position of any Hydrant

(g) Uprights shall not be inserted in the roadway or footway surfaces but shall be tenoned into sole plates as provided.

(h) If a hoarding is erected over manhole covers, service pits, valves, hydrants etc. provision shall be made for access to the manholes at all times. The sketch plan accompanying this application shall mark the position of any manhole.

(i) Building materials or spoil shall not be placed over manhole covers.

(j) Temporary crossings to buildings in course of construction shall not be made over manhole covers in the footway unless the covers are adequately protected to the satisfaction of the Authority concerned with controlling such manhole covers.

(k) Vehicles shall not cross the footpath to gain access to the site unless a temporary crossing is constructed to the satisfaction of the Council where required.

Deleted: .

(l) Upon receiving notice from the Council, the applicant shall set back the hoarding to occupy such part of the footway as the Council may direct in such notice.



- (m) Provision is to be made by the applicant that where any hut is placed upon the roof of a 'B' type hoarding, the roof of the hut be sloped towards the development site and be connected to a roof water disposal system discharging to the street, a drainage easement or to the satisfaction of the Council. No other equipment shall be placed on the hoarding unless written approval has been obtained from the Council.
- (n) Cranes, hoists, etc. shall not be placed upon the public way unless approval has been obtained in writing from the Council.
- (o) If portion of the guard rail is temporarily removed from a 'B' type hoarding that portion of the sole plate thereunder must also be removed.
- (p) Where any hoarding panel is temporarily removed, the panel must be placed within the boundary of the 'A' type hoarding.
- (q) Where it is desired to install a gate in the panels of the 'A' type hoarding the gate shall be constructed so as to swing inwards only.
- (r) Where a 'B' type overhead hoarding is erected 12 gauge 50 mm chain mesh wire shall be placed in a vertical position for the entire length of the hoarding to enclose the gap beneath the top of the 'A' panel type hoarding and the underside of the decking of the 'B' class hoarding.
- (s) The hoarding must be so constructed that it will not obstruct the view of motorists or pedestrians to traffic signals or any other traffic control device.
- (t) Pedestrian crossings must be freely accessible at all times.
- (u) The use of the roadway for the loading and unloading of vehicles is not approved by this permit. Should a 'Building Construction zone' be required, a separate application should be made to Council pursuant to the provisions of the Roads Act 1993.
- (v) The use of the roadway for the storage of material is not permitted.
- (w) Where materials are being hoisted over a public way a sign shall be attached or printed upon the front of the hoarding at the decking level with the lettering 'LIFTING OPERATIONS ABOVE'. The letters shall not be less than 300mm in height. In addition a Traffic Management Plan is to be submitted and approved by Council for these works.

**5. The following additional conditions are brought to the notice of the Applicant**

- A. Kerbing and/or guttering shall not be cut or injured in any way and wheeled or track type vehicles shall not cross over the kerbing unless provision has been made to properly protect the kerbing from damage or interference.
- B. Any water channel such as road gutters shall not be obstructed in any way and shall be kept clean and free from debris.
- C. When excavated and/or demolition materials are being removed from the site the applicant shall ensure that the streets over which the materials are being hauled be kept clear and free from debris at all times. The equipment conveying such debris or material shall be suitably covered in such a manner that will prevent such material from dropping on to the roadway. The haulage is to be along such streets as may be specified by Council's Officer or any Development Consent over the site.
- D. The applicant shall indemnify the Council and in the case of a Classified Road, the RTA:-
- (i) against all claims and expenses and costs arising from, made or recovered against the Council by any person arising out of any work done or purported to be done by the Applicant under the authority of this permit.
- (ii) against all claims and expenses and costs arising from, made or recovered against the Council by any person and against all loss damages cost and expenses incurred by the Council arising out of the failure of the Applicant to comply with the provisions of any Act, Regulation, or

any order or direction lawfully given thereunder by any person relating to any work done or purported to be done by the applicant under the authority of this permit.

A copy of all relevant insurances is to be submitted to Council prior to commencement of works.

E. The applicant shall, on demand, pay to the Council all expenses and costs incurred by the Council in respect of the repair or restoration of the footway and roadway rendered necessary as a result of any work or thing done or purported to be done by the Applicant under the authority of this Permit. The certificate of the Development Engineer in respect of such expense and costs shall be final and conclusive.

F. A Traffic Management Plan is to be submitted to Council for the erection/removal of hoardings where pedestrian or vehicular movements are disrupted.

G. A copy of this approval is to be kept on site at all times.

DRAFT